

# NAOMI

FITNESS DESIGN

2023



# TABLE OF CONTENT

- 06** MODULAR DESIGN
- 22** Cube - S And D Series
- 26** Cube - Wallmount
- 30** Cube - Outdoor
- 34** Cube - Backyard
- 36** Suspension Bridge
- 38** Boxing Rail System
- 40** 10x training
- 40** Chameleon
- 44** Racks
- 48** Contact informations





ROPE

STRENGTH

ICS

MIAMI  
FITNESS DESIGN

STORAGE

tiger

5 KG

tiger

15 KG

tiger

25 KG

tiger

15 KG

tiger

tiger

tiger

tiger

---

# NAOMI 3D CAGE VISUALIZATIONS

Cross Zone with huge cross/functional cage where every user will find something for them self! Over 20 different workout stations where you can train individually or in the group.

- You will find such a stations like:
- Endless Rope
- Peg Board & Rocky Road with climbing rocks
- Wall Ball & Rebounder
- Hand Cycle
- Pull Up Handles
- Squat Station with Safety Bars
- Gymnastic Ring Station
- Jump Station
- Labyrinth Station
- DIP & Abdominal Chair Station
- Calisthenics Station
- Workout Ladder Station

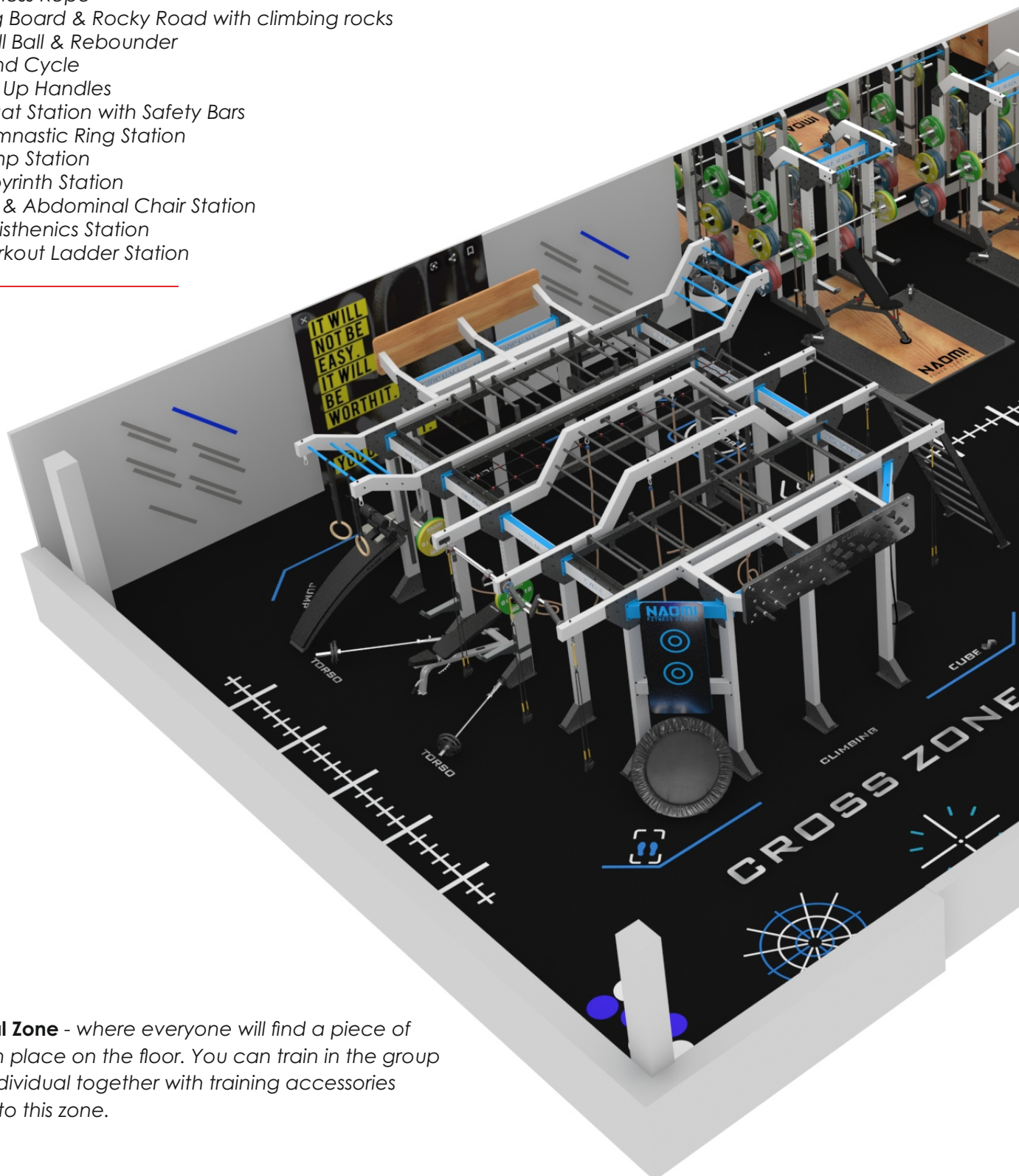

**Functional Zone** - where everyone will find a piece of them own place on the floor. You can train in the group or train individual together with training accessories assigned to this zone.

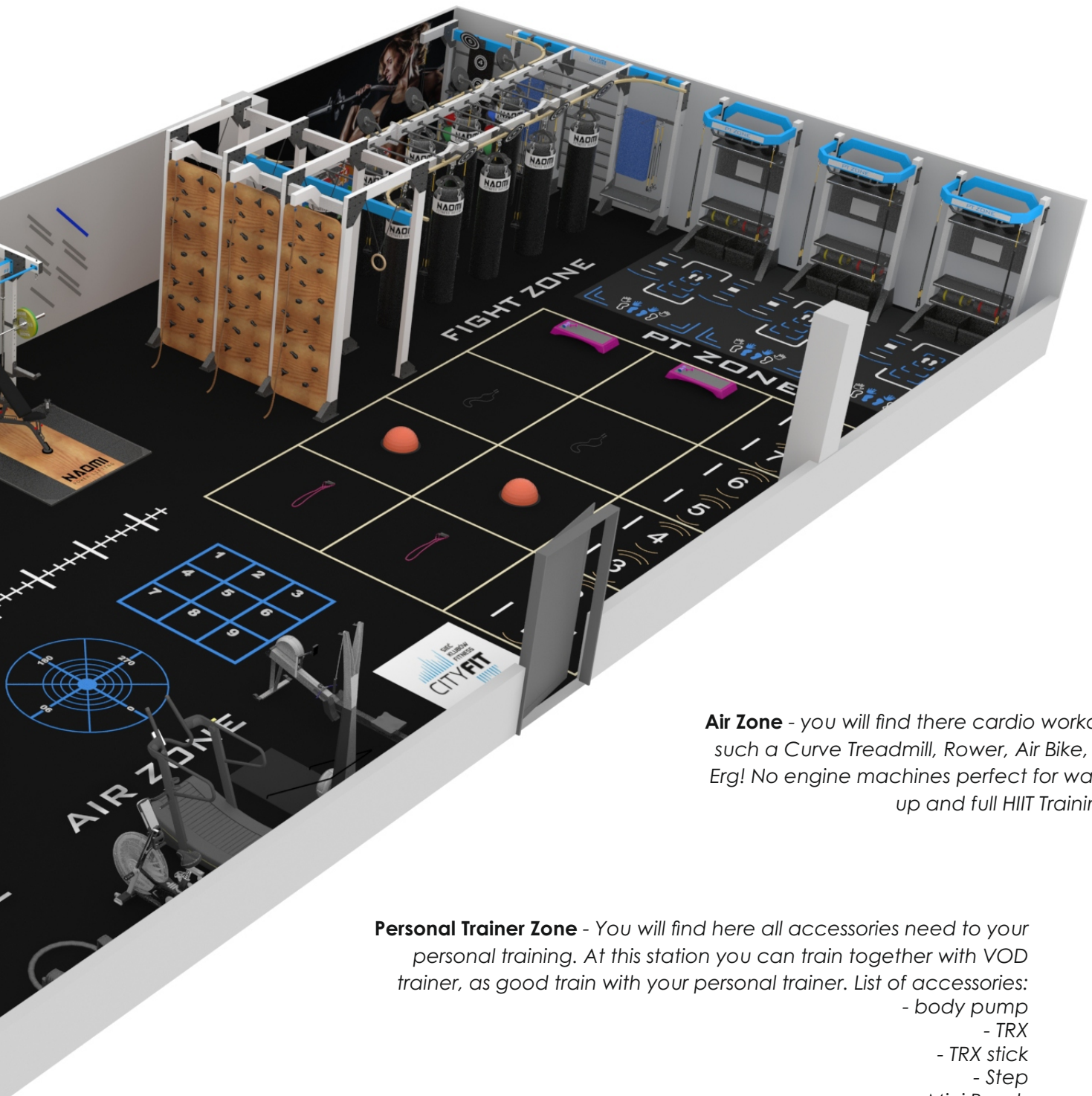

**Air Zone** - you will find there cardio workout such a Curve Treadmill, Rower, Air Bike, Ski Erg! No engine machines perfect for warm up and full HIIT Training.

**Personal Trainer Zone** - You will find here all accessories need to your personal training. At this station you can train together with VOD trainer, as good train with your personal trainer. List of accessories:

- body pump
- TRX
- TRX stick
- Step
- Mini Bands
- Pull Up Bar
- Bosu
- Power Bag
- Slam Ball
- Medicine Ball
- Roller

**Fight Fitness Zone** - You will find here great Suspension Bridge together with moving system of Boxing Bags. You can make full Boxing Training here as also fight fitness training. If you dont need boxing bags, simply you can move them on a side and train on TRX or any other suspension training. 10 places every 1,2m give you perfect space for your workout. On the side of the cage you will find Storage Stations and Wall Ball Station where special design gives you a great workout for abdominal and wall training. On the other side you will find something special, climbing rock wall with climbing rope! Inside you can feel like real Ninja Warrior thanks to gymnastics rings in 3 different hight.



## MODULAR DESIGN

Naomi Fitness Design Modular Cages – the ultimate solution for those looking to take their workout routine to the next level! Our innovative design allows for complete customization, ensuring that you get the most out of your fitness equipment.

With our modular design, you can easily add or remove components to create the perfect workout environment. From pull-up bars to weightlifting platforms, the possibilities are endless. Whether you're a beginner or a seasoned athlete, our fitness cage can be tailored to your specific needs.



10



CALISTHERNICS

30



BOXING BAG - 180cm

11



CALISTHERNICS HIGH

31



BOXING BAG - 160cm

12



RINGS

32



BOXING BAG - CUSTOM LOGO

20

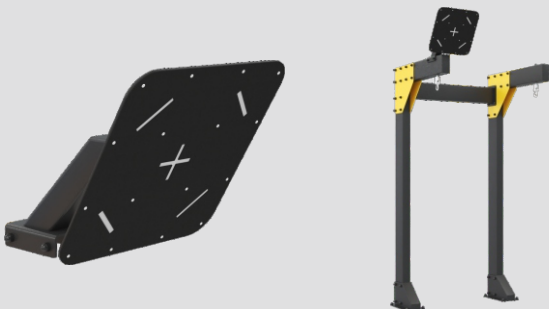

TARGET BALL<sup>2</sup>

33



AQUA BAG

# AVAILABLE MODULES - CHOICE

40

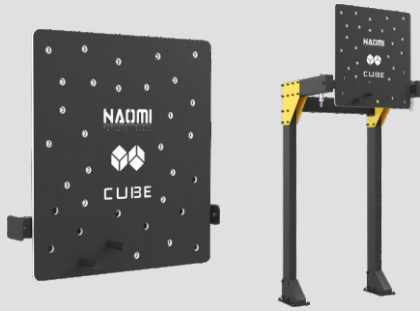

CLIMBING SINGLE STATION

60



ENDLESS ROPE

41



CLIMBING D SERIES

70



CLIMBING ROPE

42



CLIMBING S SERIES

80



BATTLE ROPE

50

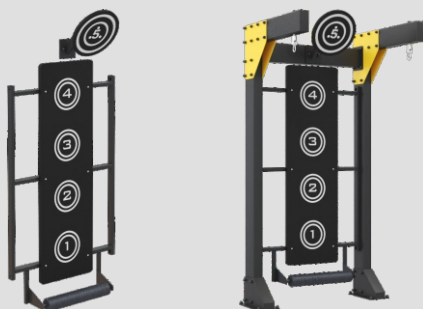

WALLBALL

90

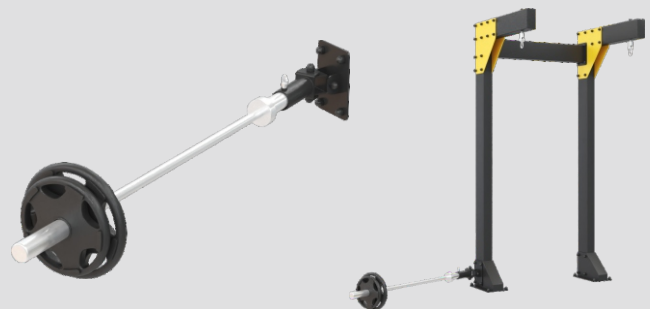

TORSO TRAINER



100

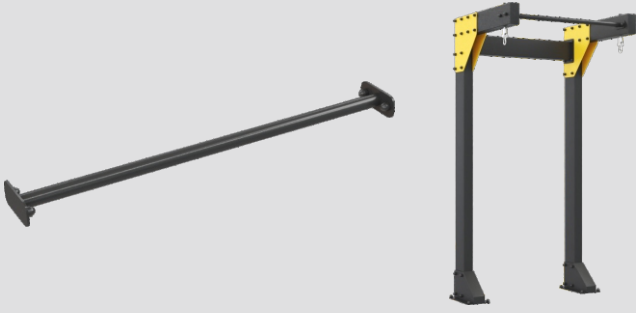

PULL UP BAR

111

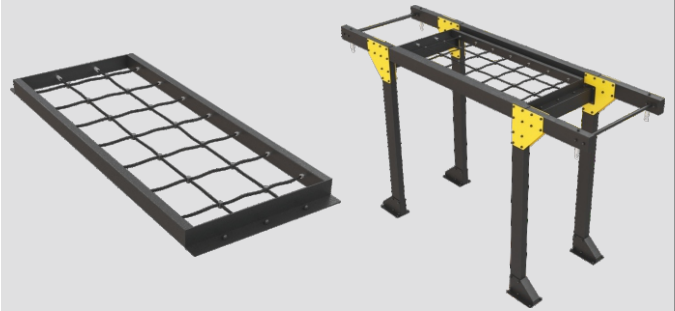

MONKEYBAR - ARMYNET

101

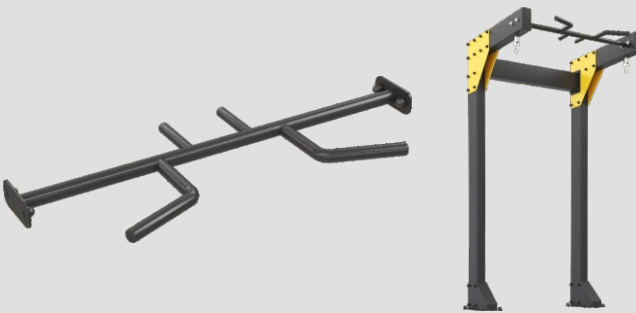

MULTI PULLUP

112



MONKEYBAR - WAVE

102



PULL UP HANDLES

113



MONKEYBAR - HANDLES

110



MONKEYBAR - STANDARD

114



MONKEYBAR - STRAIGHT

120



*DIP - AB-TRON*

130



*SQUAT*

121

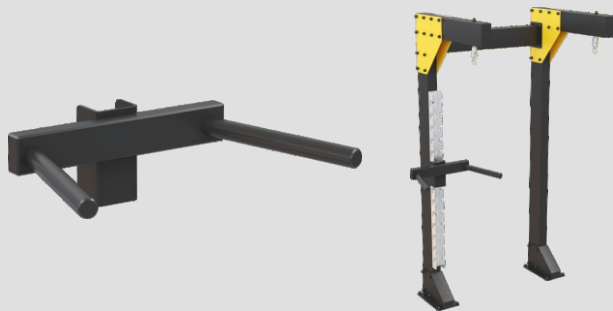

*DIP - SIMPLE*

131



*STRENGTH ARMS*

122

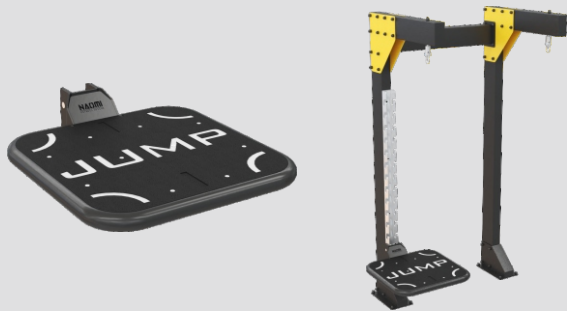

*JUMP*

140



*CYCLE*

123



*AB BENCH*

141

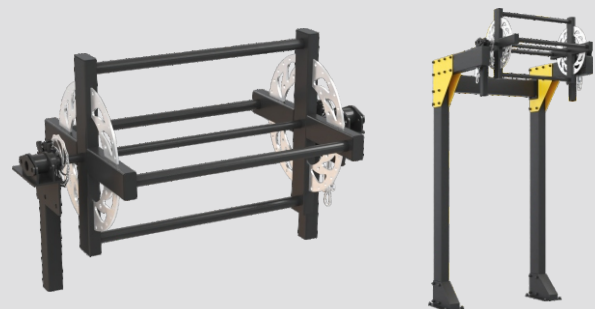

*SPIN BAR*

150

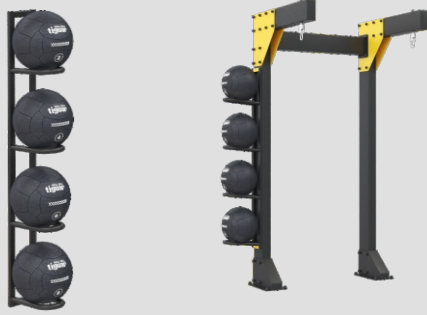

STORAGE - BALLS

154



STORAGE - STANDARD 1

151



STORAGE PLUS

155



STORAGE - SUSPENDED SHELF

152



STORAGE - PLATE HOLDER

156



STORAGE - DUMBBELL SHELF

153



STORAGE - MATS

157



STORAGE - VERTICAL SHELF

160



ONE STACK

190



SLANTED LADDER

170



REBOUNDER

191



ARMYNET

180



AB STRAPS

192

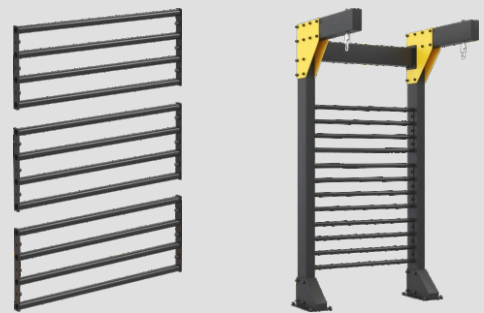

VERTICAL LADDER V2

181



GRIP BALLS

193



WORKOUT LADDER V2

200

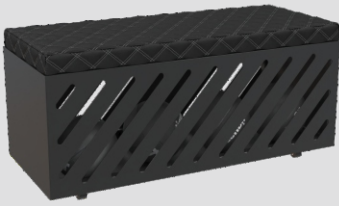

STORAGE BOX

201



TOASTER

202



DRAWER

## AVAILABLE MODULES - CHOICE

---

### MODULES - EXAMPLE SETUP

This example features the requested MODULAR design for our client. The space that the Client wants to repurpose is a squash court. We were provided with dimensions of 10 x 6.45 m. The colors are orange and black. We are using RAL colors palette. In that case, we picked RAL 2011, RAL 9005

Modules that Client requested:

- 2x - ONE STACK (160)
- 1x - PULL UP (100)
- 2x - SQUAT (130)
- 1x - MULTI PULLUP (101)
- 3x - STORAGE - PLATE HOLDER (152)
- 1x - CYCLE (140)
- 2x - STORAGE - SUSPENDED SHELF (155)
- 1x - STORAGE - MATS (153)
- 1x - WORKOUT LADDER V2 (193)
- 1x - DIP - AB-TRON (120)
- 1x - WALLBALL (50)
- 4x - TARGET BALL<sup>2</sup> (20)
- 4x - BOXING BAG - CUSTOM LOGO (32)
- 1x - BRIDGE MODULE (1)
- 1x - BOXING RAIL SYSTEM (5)

\* Walls of the court are not shown for better visual clarity of our products.



## MODULES - EXAMPLE SETUP

Example: Bridge MODULAR design.

In this case client provided us with a floor plan and asked for our BRIDGE in this space. Color RAL 9005 black.

Modules that Client requested:

- 1x - BRIDGE 980 (1)
- 17x - PULL UP (100)
- 2x - SQUAT (130)
- 1x - STORAGE - MATS (153)
- 2x - STORAGE - SUSPENDED SHELF (155)
- 1x - LADDER
- 4x - TARGET BALL<sup>2</sup> (20)
- 1x - STORAGE BOX (200)
- 1x - TOASTER (201)
- 1x - DRAWER (202)

\* Walls of the court are not shown for better visual clarity of our products.



## AVAILABLE MODULES - CHOICE

---

### MODULES - EXAMPLE SETUP

Example: Near-Wall Storage MODULAR design.  
This one is a Functional storage solution.  
Client arranged 4 Modules 100cm

- 1x - WORKOUT LADDER
- 1x - VERTICAL LADDER
- 1x - WALLBALL (50)
- 2x - STORAGE - BALLS (150)
- 2x - STORAGE - SUSPENDED SHELF (155)
- 1x - VERTICAL LADDER
- 2x - PULL UP (100)
- 1x - MULTI PULLUP (101)
- 1x - ENDLESS ROPE (60)

\* Walls of the court are not shown  
for better visual clarity of our products.

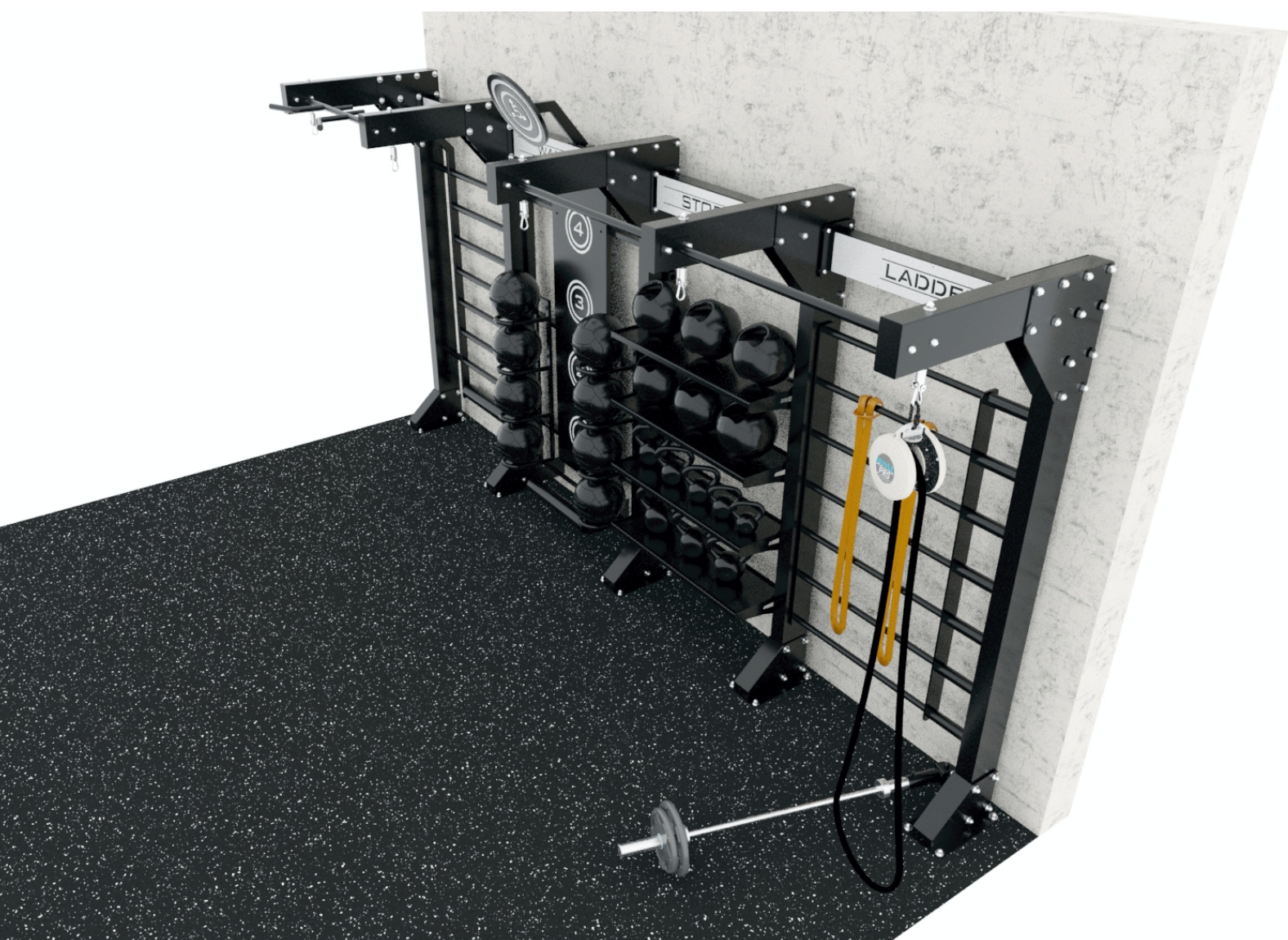



## MODULES - EXAMPLE SETUP

Example: S200 based modular design

- 1x - WALLBALL (50)
- 2x - PULL UP (100)
- 1x - SQUAT (130)
- 1x - STORAGE - SUSPENDED SHELF (155)
- 1x - WORKOUT LADDER
- 1x - BOXING BAG - CUSTOM LOGO (1)
- 1x - DIP - SIMPLE (121)
- 1x - AB BENCH (123)
- 1x - CUSTOM LOGO PLATE

\* Walls of the court are not shown for better visual clarity of our products.

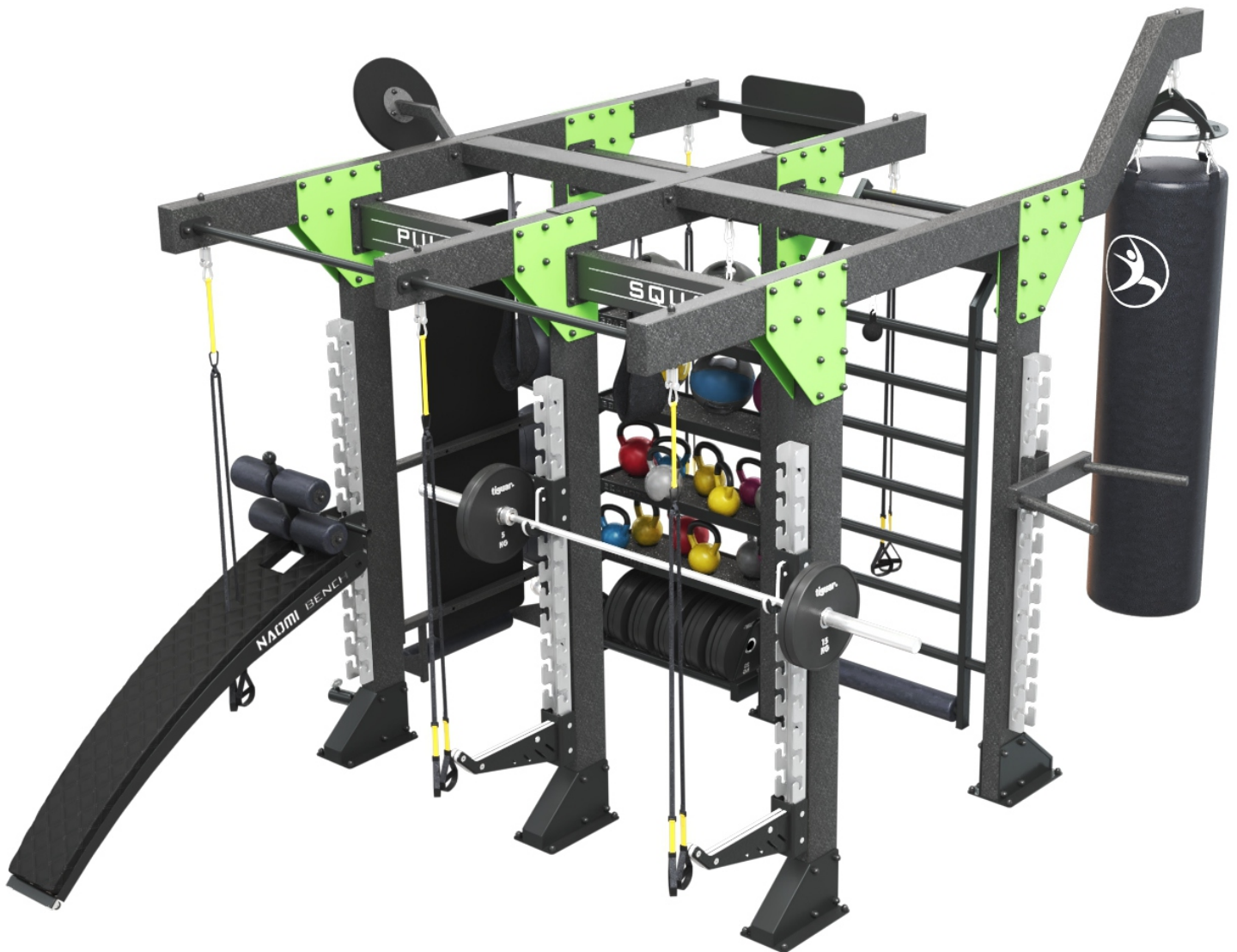

## AVAILABLE MODULES - CHOICE

---

### MODULES - EXAMPLE SETUP

Example: STORAGE PLUS modules

Here is an example of our STORAGE PLUS. STORAGE PLUS adds storage capabilities to the modules that previously were not possible. You could not combine „Storage” and „shelves”. By putting storage module at the back of the station we sacrifice a little bit of space but the overall design is more compact and versatile

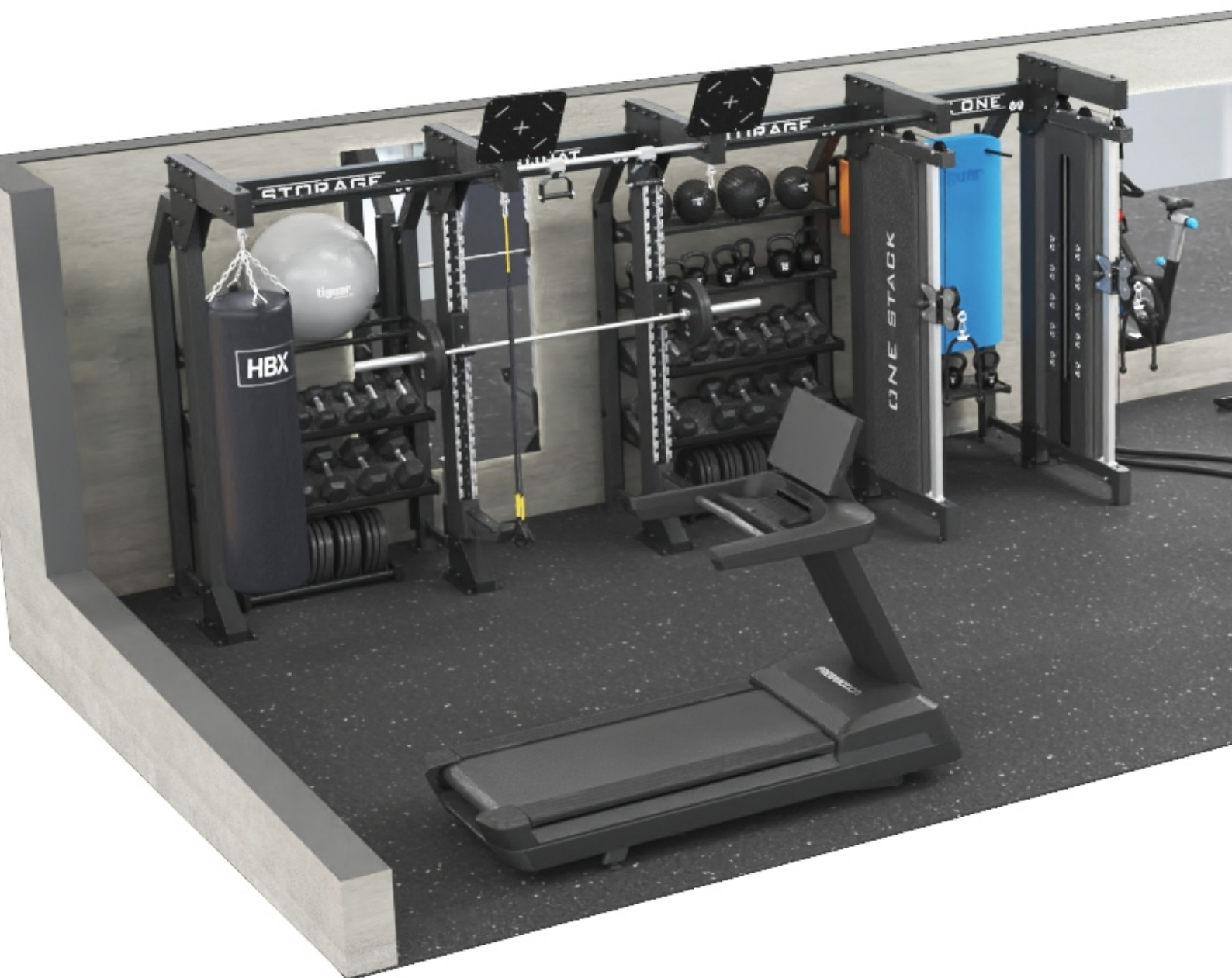

## HIGHLITING - STORAGE PLUS CAGE

- 3x - STORAGE PLUS (50)
- 2x - STORAGE - DUMBBELL SHELF (165)
- 1x - STORAGE - MATS (153)
- 2x - PULL UP (100)
- 2x - SQUAT (130)
- 1x - TARGET BALL<sup>2</sup>
- 1x - BOXING BAG - 160cm (31)
- 1x - DIP - SIMPLE (121)
- 1x - AB BENCH (123)
- 1x - TARGET BALL<sup>2</sup> (20)
- 2x - ONE STACK (160)
- 1x - BATTLE ROPE (90)
- 1x - PULL UP HANDLES (110)
- 2x - TOASTER (201)



## AVAILABLE MODULES - CHOICE

---

Example: CUSTOM FRAME PROJECT

We can also provide our clients with a fully custom build based on our frame. The project features our Base Frame and Rail system. Simple, Elegant, and Functional at the same time.

1x - BASE FRAME (based on WEIGHT)

1x - custom BOXING RAIL SYSTEM



## HIGHLIGHTING - IMMERSIVE DESIGN

### Emphasizing Immersive Design Excellence

Our team of seasoned designers and developers specializes in the 3D immersive design, boasting years of experience crafting bespoke solutions for clients across the globe. We possess the knowledge and proficiency necessary to bring your vision to life.

Throughout each project phase, we collaborate intimately with our clients to guarantee that their aspirations are impeccably manifested in the end product. Our approach commences with comprehending your unique circumstances and developing a tailored 3D immersive experience meticulously designed to align with your distinct objectives and requirements.

Contact us today to explore our array of services and transform your vision into reality.

- 1x - BOSU ADDON
- 1x - VERTICAL LADDER V2 (192)
- 1x - REBOUNDER (170)
- 1x - STORAGE - MATS (153)
- 1x - STORAGE - SUSPENDED SHELF (155)
- 3x - PULL UP BAR (100)
- 1x - ENDLESS ROPE (60)
- 1x - DRAWER (202)

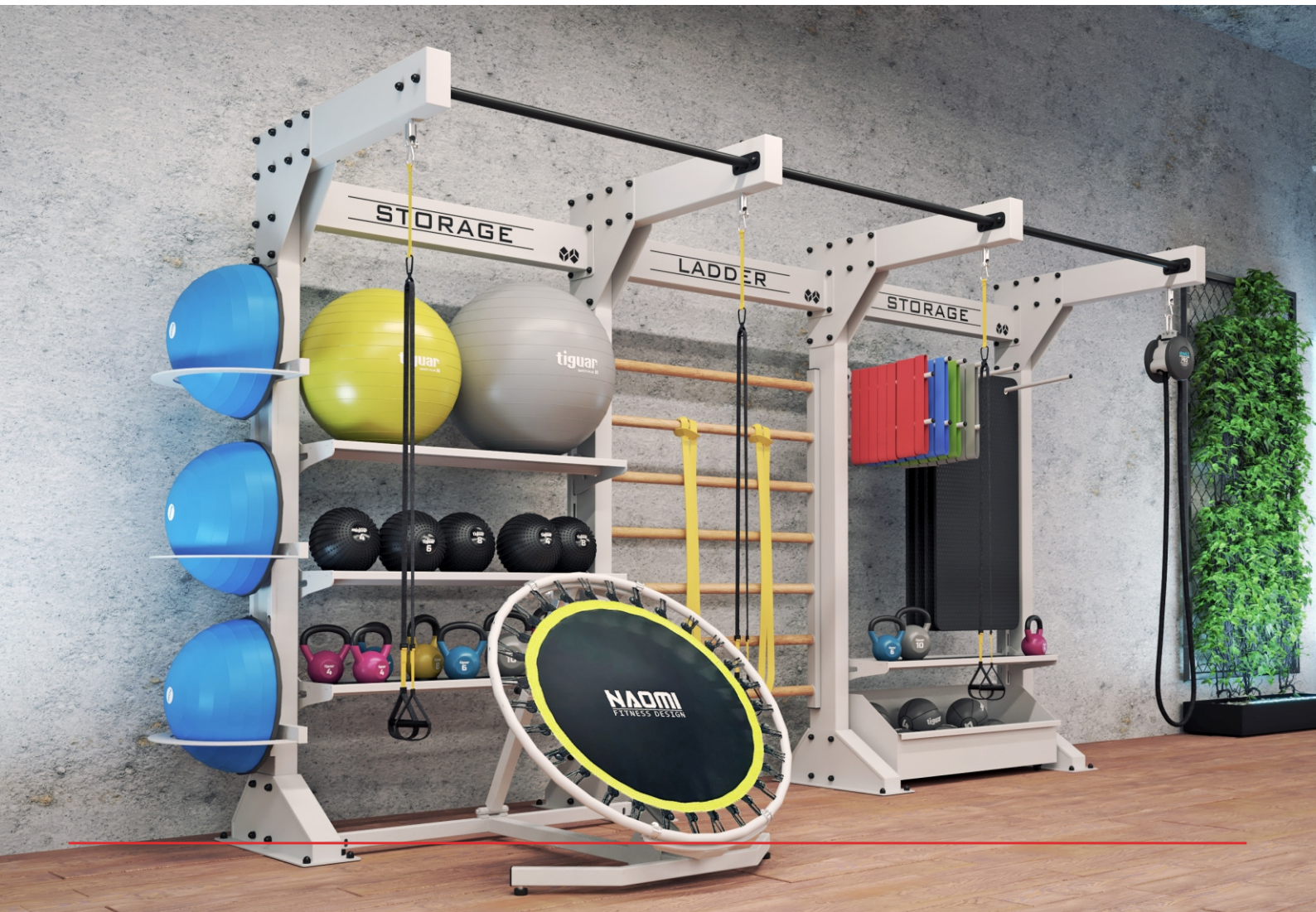

# cube line featuring ds00





## CUBE D200

DIMENSIONS (bounding box)  
510cm x 370cm x 290cm

36 m<sup>2</sup> 11 users

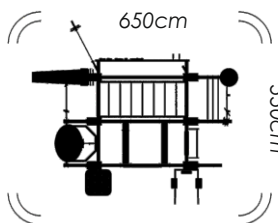

D200 is the smallest cage of this line. This is a perfect opportunity for smaller clubs to host functional fitness classes and still maintain maximum floor space for other activities. Remember, you still have an option to pick your stations to satisfy individual needs for the most functional rig. After all, the letter "D" stands for Dynamic.



## CUBE D300

DIMENSIONS (bounding box)  
580cm x 480cm x 290cm

42 m<sup>2</sup> 14 users

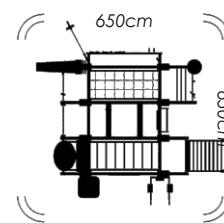

Space savings don't mean that you should sacrifice on versatility or design. While D300 is scaled down to fit almost any space, it still maintains the overall features of its larger predecessors. For club operators that still want to wow their audience while maintaining a small footprint, this model is for you!



## CUBE D400

DIMENSIONS (bounding box)  
590cm x 580cm x 290cm

49 m<sup>2</sup> 18 users

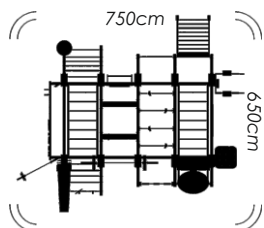

A smaller scale of the Cube without sacrificing any of the usability of its big brother. Modular by design, means that you can pick and choose any station to your liking. If you wish to, you can even duplicate many of the stations, to really dial in your preference.



## CUBE D500

DIMENSIONS (bounding box)  
700cm x 580cm x 290cm

55 m<sup>2</sup> 20 users

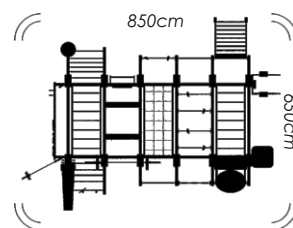

This Cube has it all! The largest in the series it showcases all the components that made the Cube series an instant classic. From strength to agility exercises, this one bears it all. With ample workout space, you'll be sure that the club goer will not feel restricted or crowded.



**cube line  
featuring s400**





## CUBE S200

DIMENSIONS (bounding box)  
405cm x 360cm x 290cm

30 m<sup>2</sup> 9 users

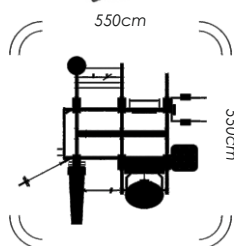

When smaller is better or needed, the S200 is here! The smallest rig in this line, it will perform just as good as its larger counterparts. Now, facilities with confined spaces can entertain their members and engage them in a functional fitness environment.



## CUBE S300

DIMENSIONS (bounding box)  
470cm x 405cm x 290cm

36 m<sup>2</sup> 12 users

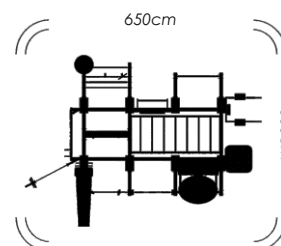

Not enough space for a fully functioning multi-fitness rig? Not with S300! This one will surely satisfy your needs, when floorspace is at a premium. As always, you can pick and choose your individual stations to your liking.



## CUBE S400

DIMENSIONS (bounding box)  
580cm x 480cm x 290cm

41 m<sup>2</sup> 15 users

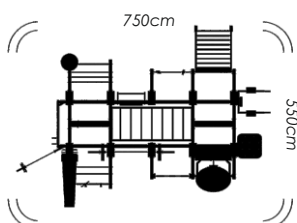

Slightly smaller than its predecessor, S400 still affords the possibility of having a great workout in less space. By design, this unit has all the best features of S500 in a more compact, seamless arrangement.



## CUBE S500

DIMENSIONS (bounding box)  
690cm x 480cm x 290cm

47 m<sup>2</sup> 17 users

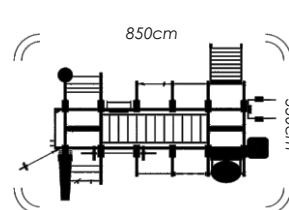

This model is a combination of all the best stations with full integration of new methodologies of functional fitness workout. S500 allows the club operators to triangulate all the workouts of their members to assure their maximum satisfaction.

# cube line wallmount

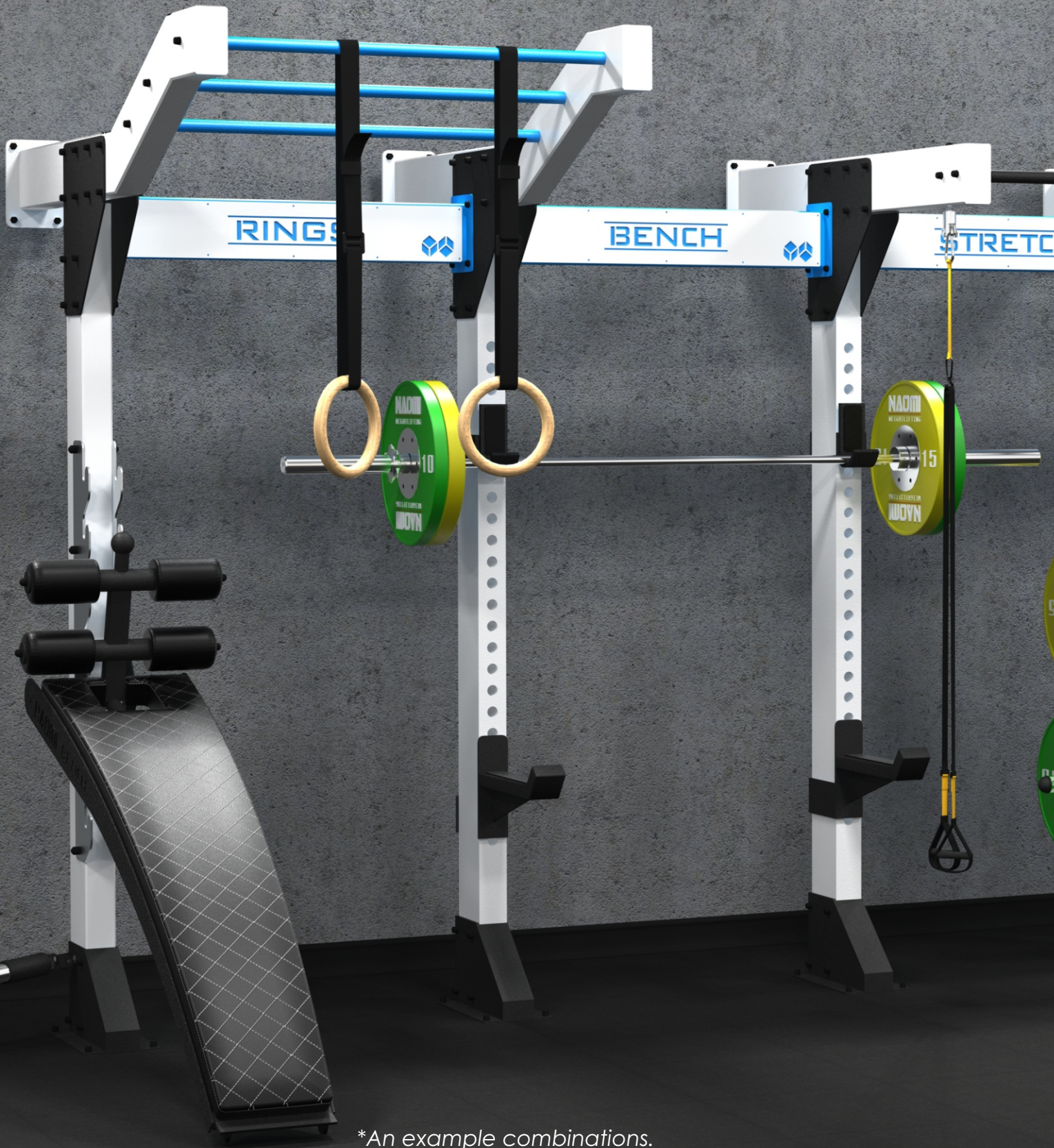

*\*An example combinations.  
You can choose any of the stations and connect them in a suitable way that  
suits your surface and the needs of the exercisers*



### WM 2 BAY

DIMENSIONS (bounding box)  
340cm x 220cm x 240cm

□ 17 m<sup>2</sup>    👤 5 users

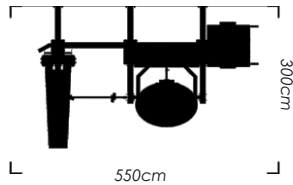

Some called it "cute" some called it "dainty" We call it outstanding! This unit accommodates the clubs with minimal functional fitness space.



### WM 3 BAY

DIMENSIONS (bounding box)  
447cm x 220cm x 260cm

□ 20 m<sup>2</sup>    👤 6 users

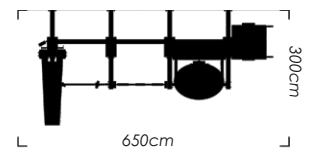

This unit will shine in the tightest of spaces! Idealist will enjoy the suspension exercises, while the calisthenics enthusiasts will be pleased with its features as well.



### WM 4 BAY

DIMENSIONS (bounding box)  
556cm x 220cm x 260cm

□ 23 m<sup>2</sup>    👤 7 users

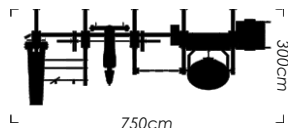

Notable feature of this unit is how harmoniously it combines all the exercises in a very small footprint. WM 4 BAY affords the club owners of having a great rig without giving up space.



### WM 5 BAY

DIMENSIONS (bounding box)  
660cm x 220cm x 260cm

□ 26 m<sup>2</sup>    👤 8 users

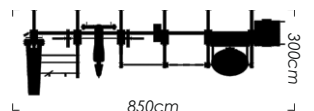

With 7 or 8 posts this design is sturdy and stable. By attaching the rig to the wall, you'll optimize your space for other workouts as well.



cube line  
extended wallmount



**WM 2 BAY**  
EXTENDED

DIMENSIONS (bounding box)  
340cm x 220cm x 240cm

□ 17 m<sup>2</sup>    👤 5 users

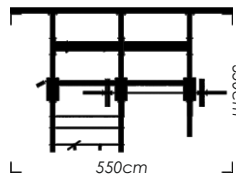

When you simply must have the "best of" but require less space to do it, D300 is your perfect choice. Standard functional fitness exercises coupled with innovative features make this rig extraordinary.



**WM 3 BAY**  
EXTENDED

DIMENSIONS (bounding box)  
447cm x 220cm x 260cm

□ 20 m<sup>2</sup>    👤 6 users

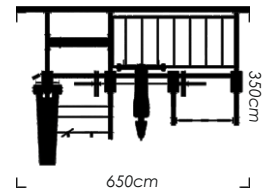

When you simply must have the "best of" but require less space to do it, D300 is your perfect choice. Standard functional fitness exercises coupled with innovative features make this rig extraordinary.



**WM 4 BAY**  
EXTENDED

DIMENSIONS (bounding box)  
556cm x 220cm x 260cm

□ 23 m<sup>2</sup>    👤 7 users

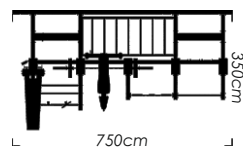

Smaller wall space? No a problem! You can still get the 4bay and satisfy your craving for a great workout. Nothing is given up here! This model is an ideal combination of everything that's great about functional fitness, in less space!



**WM 5 BAY**  
EXTENDED

DIMENSIONS (bounding box)  
660cm x 220cm x 260cm

□ 26 m<sup>2</sup>    👤 8 users

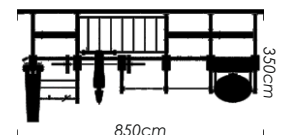

The entire workout is brought forward in this seamless design. Sturdy design coupled with the ability to pick your own stations, makes this rig a must have.



cube line  
outdoor d series



### CUBE D200 OUTDOOR

DIMENSIONS (bounding box)  
494cm x 512cm x 293cm

33 m<sup>2</sup> 11 users

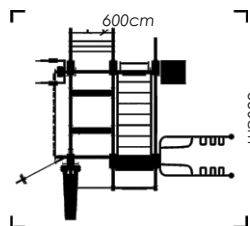

D200 is the smallest cage of this line. This is a perfect opportunity for smaller clubs to host functional fitness classes outdoors and still maintain maximum floor space for other exercises.



### CUBE D300 OUTDOOR

DIMENSIONS (bounding box)  
620cm x 583cm x 293cm

45 m<sup>2</sup> 14 users

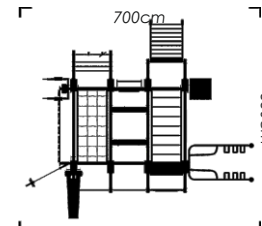

Space savings don't mean that you should sacrifice on versatility or design. While D300 is scaled down to fit almost any space, it still maintains the overall features of its larger predecessors. For club operators that still want to wow their audience while maintaining a small footprint, this model is for you!



### CUBE D400 OUTDOOR

DIMENSIONS (bounding box)  
730cm x 583cm x 293cm

52 m<sup>2</sup> 18 users

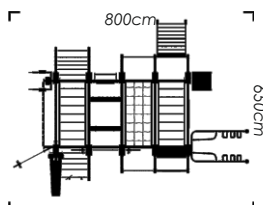

A smaller scale of the Cube without sacrificing any of the usability of its big brother. Modular by design, means that you can pick and choose any station to your liking. If you wish to, you can even duplicate many of the stations, to really dial in your preference.



### CUBE D500 OUTDOOR

DIMENSIONS (bounding box)  
835cm x 583cm x 293cm

26 m<sup>2</sup> 8 users

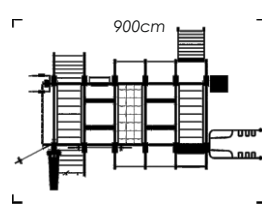

This Cube has it all! The largest in the series it showcases all the components that made the Cube series an instant classic. From strength to agility exercises, this one bears it all. With ample workout space, you'll be sure that the club goer will not feel restricted or crowded.

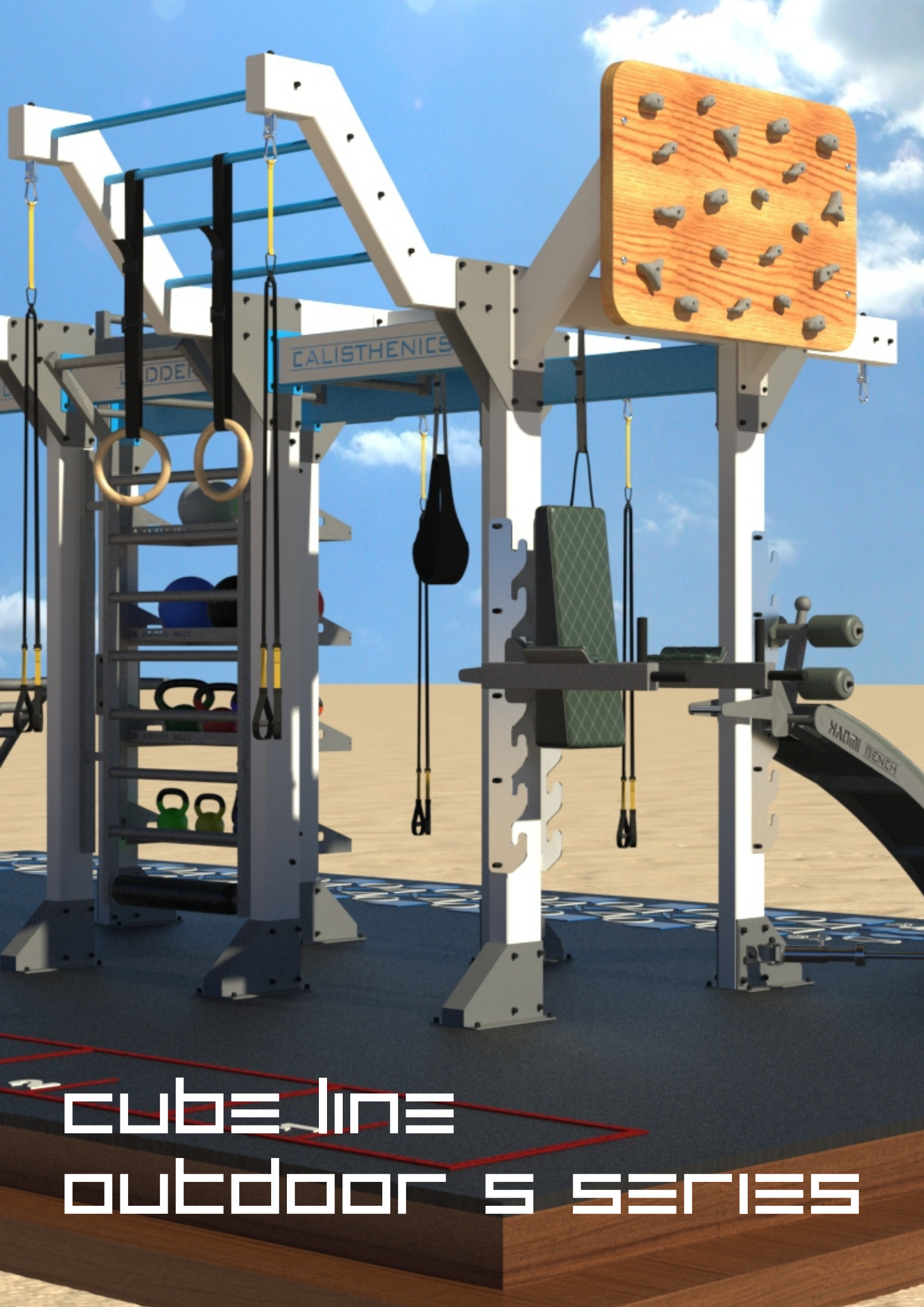

cube line  
outdoor s series





### CUBE S200 OUTDOOR

DIMENSIONS (bounding box)  
509cm x 389cm x 293cm

27 m<sup>2</sup> 9 users

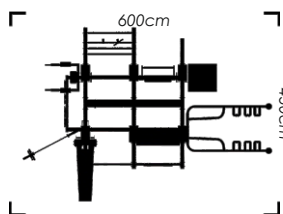

When smaller is better or needed, the S200 is here! The smallest rig in this line, it will perform just as good as its larger counterparts. Now, facilities with confined spaces can entertain their members and engage them in a functional fitness environment.



### CUBE S300 OUTDOOR

DIMENSIONS (bounding box)  
614cm x 389cm x 293cm

32 m<sup>2</sup> 17 users

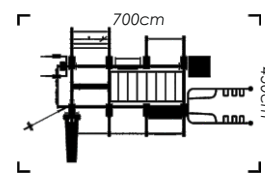

Not enough space for a fully functioning multi-fitness rig? Not with S300! This one will surely satisfy your needs, when floorspace is at a premium. As always, you can pick and choose your individual stations to your liking.



### CUBE S400 OUTDOOR

DIMENSIONS (bounding box)  
727cm x 481cm x 293cm

40 m<sup>2</sup> 15 users

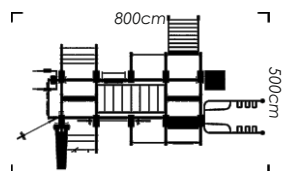

Slightly smaller than its predecessor, S400 still affords the possibility of having a great workout in less space. By design, this unit has all the best features of S500 in a more compact, seamless arrangement.



### CUBE S500 OUTDOOR

DIMENSIONS (bounding box)  
838cm x 481cm x 293cm

45 m<sup>2</sup> 17 users

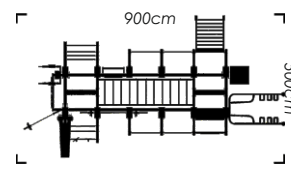

This model is a combination of all the best stations with full integration of new methodologies of functional fitness workout. S500 allows the club operators to triangulate all the workouts of their members to assure their maximum satisfaction.

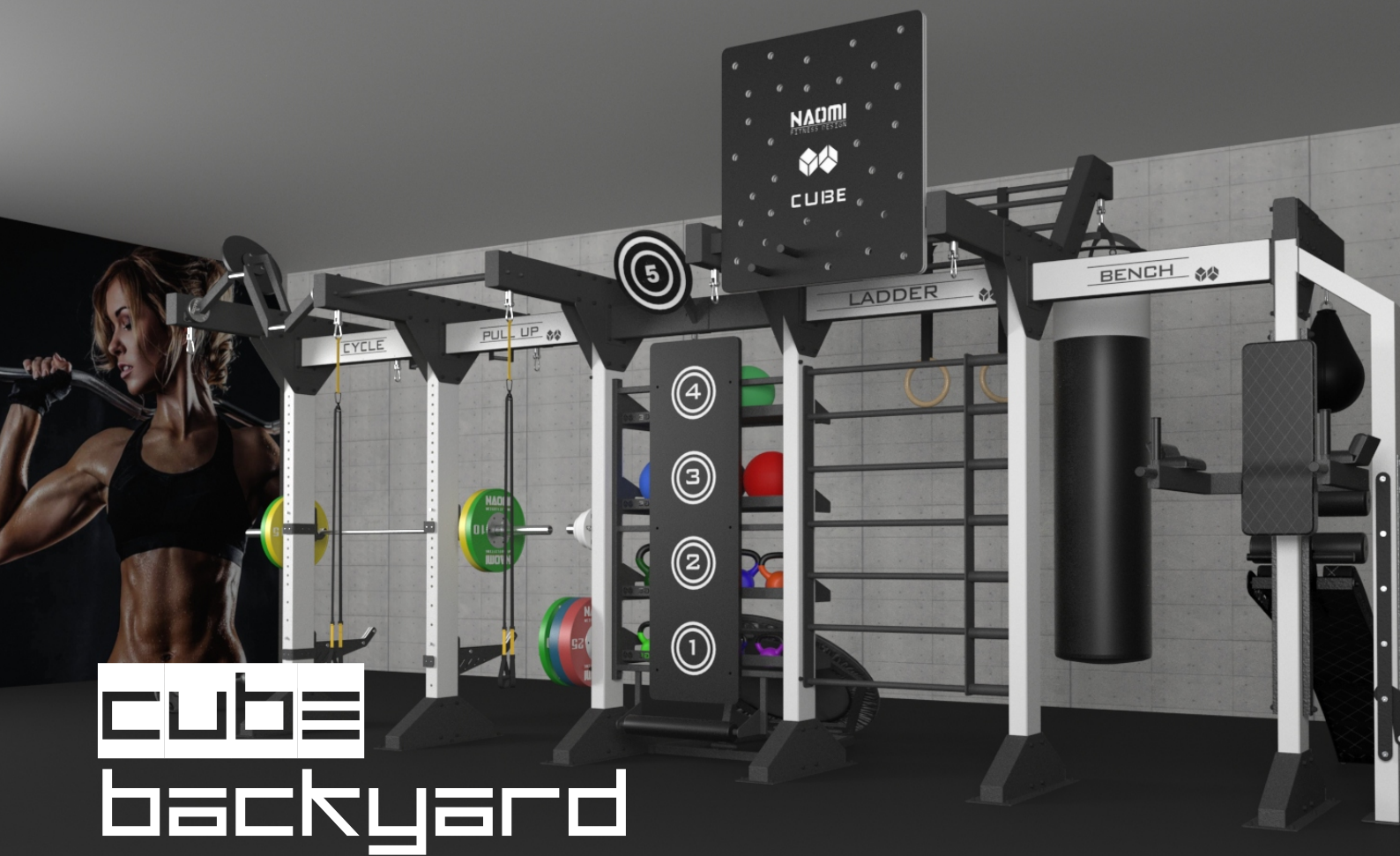

# cube backyard



## backyard 01

DIMENSIONS (bounding box)  
200cm x 155cm x 285cm

9 m<sup>2</sup> 4 users

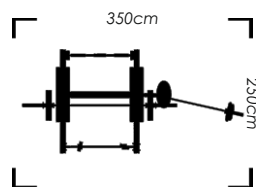

## backyard 02

DIMENSIONS (bounding box)  
630cm x 560cm x 300cm

12 m<sup>2</sup> 6 users

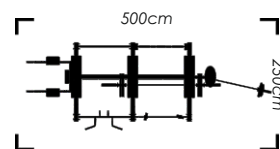

Very small but very unique, you will find here 4 users working at the same time. Very limited space cuz you need just 6 sqm to use! You have here squat stations also with safeties, also moving pull up handles, cycle station, 4 suspension anchoring points and 2 x torso trainer!

This model focuses on squat and pull up stations, you will find here all 4 pull up stations that give you all what you need for your back and arm workout, also down stations like Torso, Squat and DIP and Abdominal Throne.



### backyard 03

DIMENSIONS (bounding box)  
470cm x 210cm x 306cm

18 m<sup>2</sup> 8 users

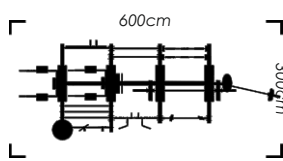

Here we have a lot of more to do. We can use 8 stations for multi use, so the exercise we can do a lot more! Apart from squat and safeties, we also have a calisthenics ladder where you can hang Gim Rings, workout ladder, Climbing Peg Board, and punch bag! So many on so not many square meters!

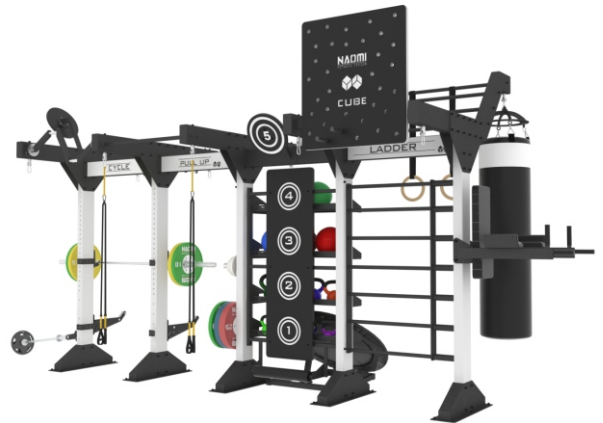

### backyard 04

DIMENSIONS (bounding box)  
668cm x 210cm x 306cm

21 m<sup>2</sup> 10 users

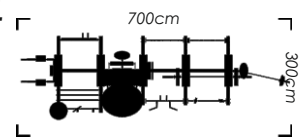

On this bigger cage at the same time can train 10 people, not only they will find a lot of exercise for every part of the body, but they will have a lot of fun, cuz all training is in cycle, you can swap easy with another user! Beside all stations from smaller models, you will find here great Wall Ball where you can sit on the ground and use 5 targets

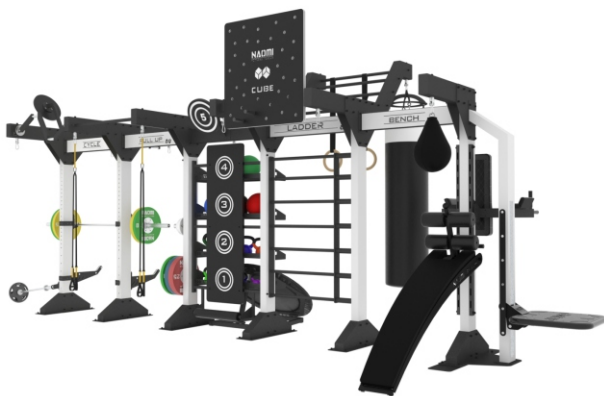

### backyard 05

DIMENSIONS (bounding box)  
700cm x 290cm x 306cm

30 m<sup>2</sup> 13 users

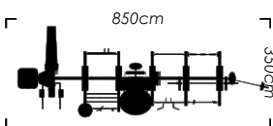

The biggest from BackYard line! 12 stations for 13 users at the same time. How we did it, very easy, nothing is impossible for Naomi. All stations in the row need less space in the room. This cage gives you maximum of workout and not repeat stations. Every single one takes you at different lever of your possibility.

A unique line of Backyard Line where functionality is used to the maximum, together with space saving.

In BackYard Line posts stand in a row, and the station is used on each side, which saves us space, additionally gives us uniqueness and full use of small space for group activities. Any stations we can combine for you, so just let us know what you need and we will create the model especially for your needs. This model can be used indoors, or outdoors.

# COISSUES

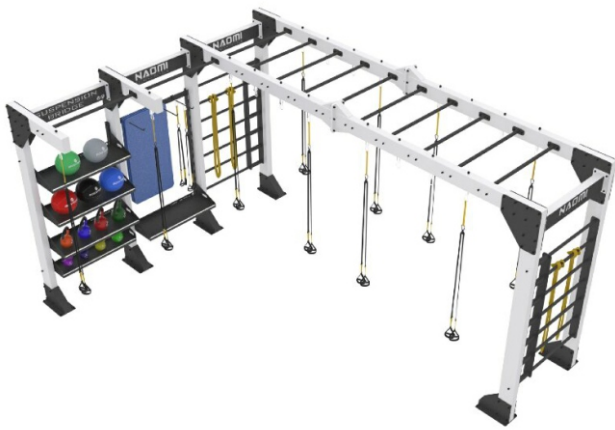

## BRIDGE 480

SINGLE

DIMENSIONS (bounding box)  
480cm x 330cm x 250cm

23 m<sup>2</sup> 8 users

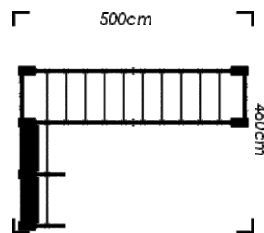

## BRIDGE 720

SINGLE

DIMENSIONS (bounding box)  
720cm x 330cm x 250cm

34 m<sup>2</sup> 13 users

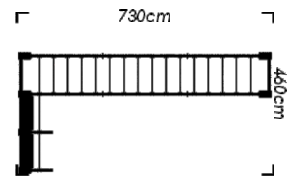

Small in size, but large in features! 18 anchoring points allow the club operators to fully engage 8 users at a time. Again, following the natural model of fitness ecosystem, the accessories racks are present to complete your total body exercise

Top design in a smaller shape! This is what Bridge XL brings to the table. 28 anchoring points with ability to work out 13 users makes this unit a must have for clubs with less space!



Modular solutions that meet all needs of functional training and storage needs.

- You can chose any configuration of storage that will work the best for your facility
- Bridges can be made at 480 cm, 720 cm, or 960 cm long
- Standard high of 250 cm, also available any hight that you wish.
- Add-ons: wall bars, shelf for free weights/rollers, stability ball shelf, mat holder, dip station, pull-up bar, and storage drawer, hand cycle, squat station, torso trainer and any station from CUBE system
- Connect additional bridges or bays for unlimited training possibilities.
- Chose colour, options, accessories, and and enjoy your configuration



## BRIDGE 920

SINGLE

DIMENSIONS (bounding box)  
990cm x 340cm x 250cm

45 m<sup>2</sup> 26 users

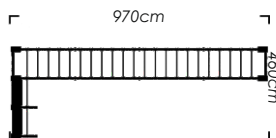

## BRIDGE 720

DOUBLE

DIMENSIONS (bounding box)  
730cm x 340cm x 250cm

51 m<sup>2</sup> 24 users

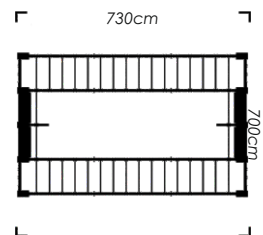

38 anchoring points allows for up to 26 users to take advantage of working out together. Slightly smaller than its predecessor, this unit still allows for open movement of ample amount of users

What's better than one Bridge! Well, two of them!. Incredible 54 anchoring points allows for 24 users to work out at the same time.

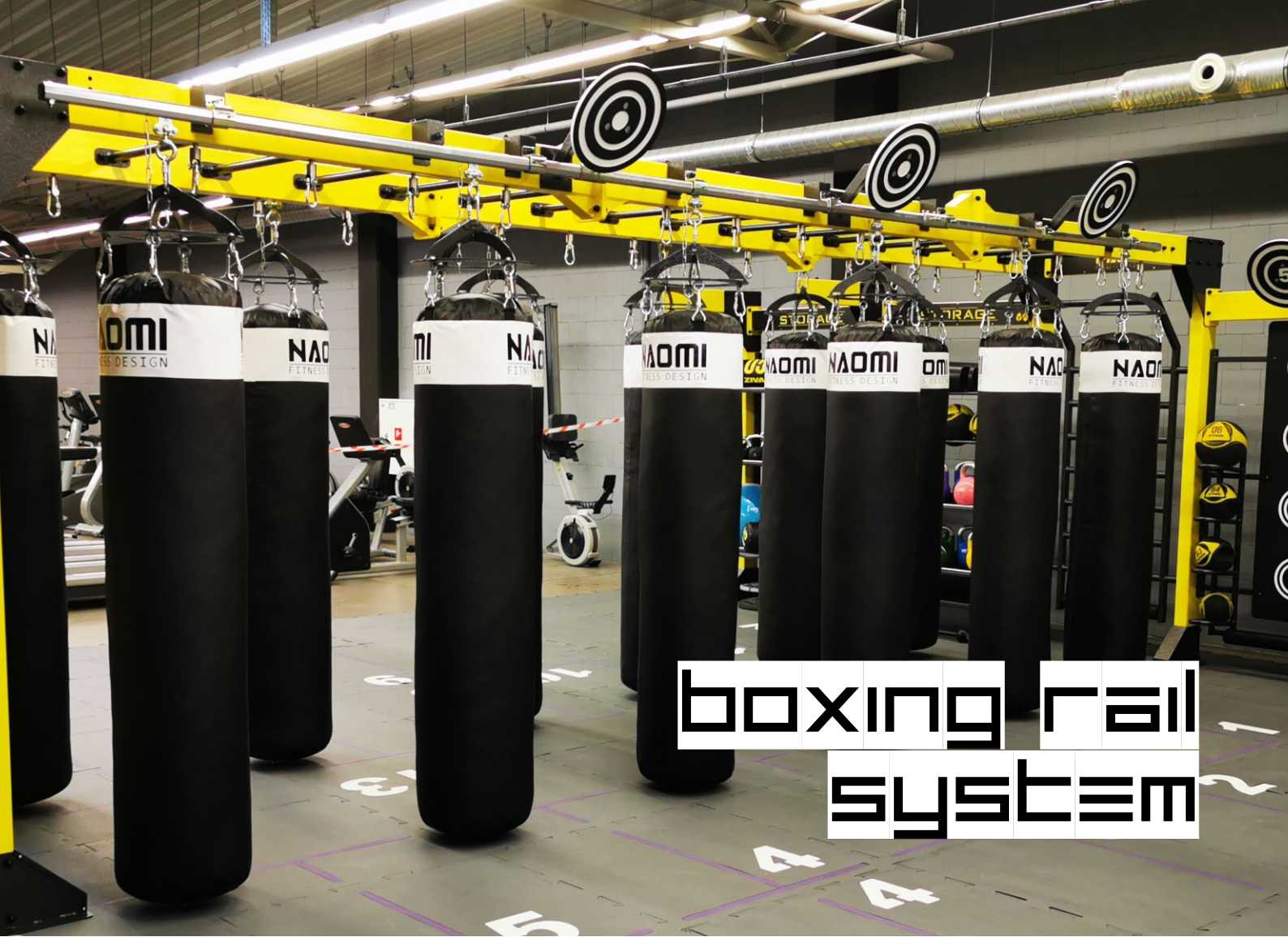

# boxing rail system



## BOXING RAIL 4x BAGS

DIMENSIONS : 435cm x 660cm x 270cm

□ 29 m<sup>2</sup>    👤 8+ users



## BOXING RAIL 5x BAGS

DIMENSIONS : 485cm x 760cm x 270cm

□ 37 m<sup>2</sup>    👤 10+ users



BOXING RAIL  
6x BAGS

DIMENSIONS : 485cm x 860cm x 270cm

□ 42 m<sup>2</sup>    👤 12+ users



BOXING RAIL  
7x BAGS

DIMENSIONS : 535cm x 960cm x 270cm

□ 52 m<sup>2</sup>    👤 14+ users



BOXING RAIL  
9x BAGS

DIMENSIONS : 480cm x 1350cm x 270cm

□ 65 m<sup>2</sup>    👤 18+ users

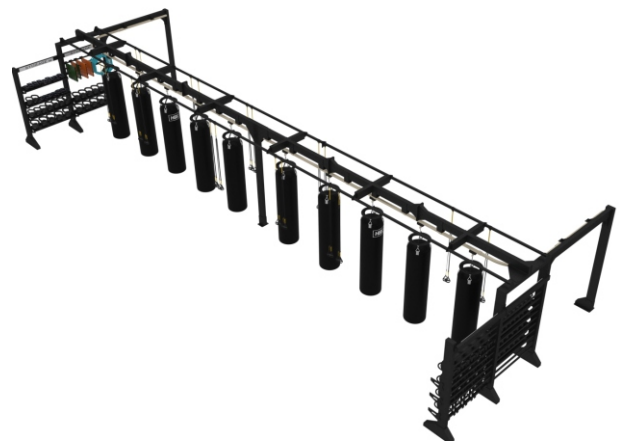

BOXING RAIL  
10x BAGS

DIMENSIONS : 480cm x 1450cm x 270cm

□ 70 m<sup>2</sup>    👤 20+ users

# 10X TRAINING





## WHY 10X TRAINING

- Social experience creating unique club culture
- It is all about fun and results – your USP
- Added value in the areas of sales and retention strategy
- Simple to manage an effective and safe training concept
- Comprehensive team training included
- Technology integration – competitive advantage

## RESULTS ARE THE KEY

- Social “experience” based around team training
- Novelty and tribal connection
- Fun, motivation, energy, sweat and results
- Training variety – constantly changing workouts
- Designed for all levels of fitness experience
- Excellent way to create a healthy lifestyle habits
- Male and female clients of all ages and lifestyle groups
- Ideal for those who need training guidance and support
- Members looking for an exciting new style of training
- Time and workout flexibility conscious individuals

## EXAMPLE 10X CONFIGURATIONS

### 10X 2 x 4 STATIONS



### 10X 2 x 2 STATIONS



### 10X 2 + 5 STATIONS

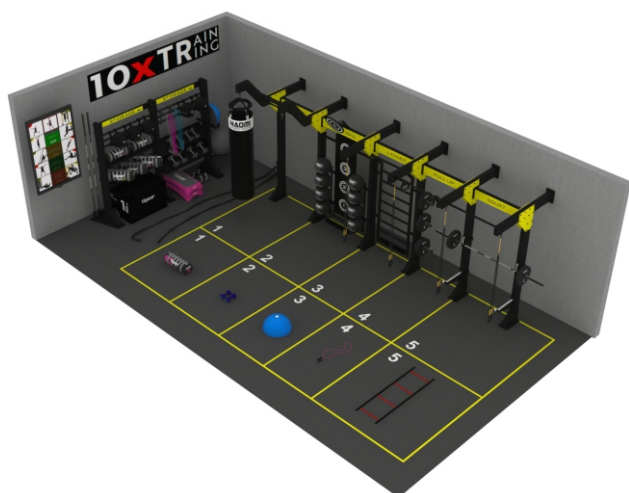

### 10X 2 + 8 STATIONS



# CHAMELEON



## SILVER

DIMENSIONS (bounding box)  
520cm x 390cm x 270cm

30 m<sup>2</sup> 9 users

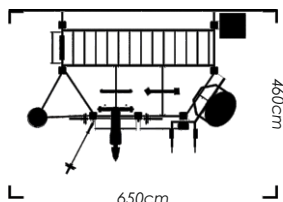

## GOLD

DIMENSIONS (bounding box)  
630cm x 560cm x 300cm

49 m<sup>2</sup> 13 users

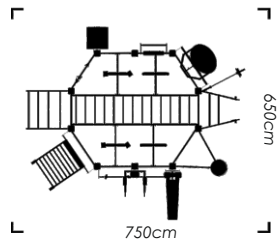

The ideal choice for those fitness clubs that value a full modular functional fitness rig and all the benefits of customization. Chameleon Silver gives you opportunity to train 9 users at the same time.

Chameleon Gold is created for typical circle training with 13 stations aloud to train 13 people at the same time. Also here you can have a great customization of any station from bigger cage family.



## TITANIUM

DIMENSIONS (bounding box)  
700cm x 550cm x 300cm

55 m<sup>2</sup> 17 users

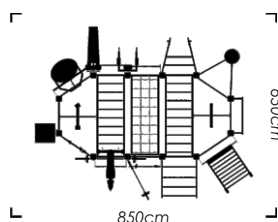

Chameleon Titanium is strong as the name! 16 users can train at the same time. Different stations, 3 different monkey bars! You can find here also cross stations as also pure functional.

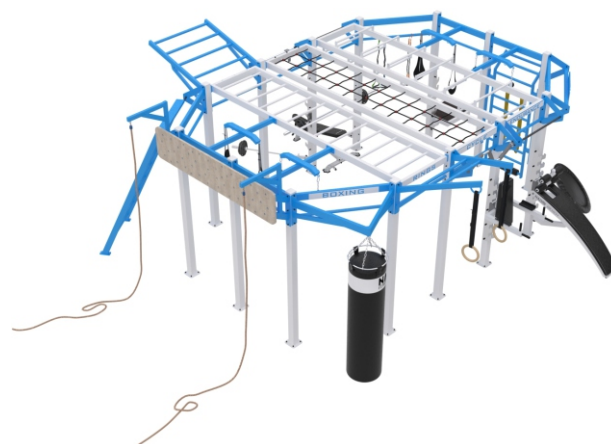

## DIAMOND

DIMENSIONS (bounding box)  
835cm x 650cm x 300cm

75 m<sup>2</sup> 25 users

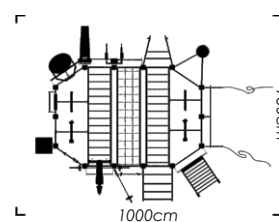

Diamond is one of the most sell big units. He's strong circle desing give you possibility to train with 21 people at the same time. Every one will find something for good training. Enough space and enough stations as long for beginners and most advances users. No one will be disappointed with Chameleon Diamond!

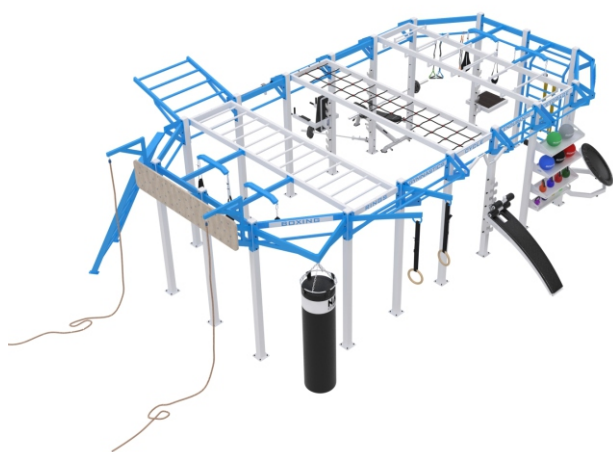

## PLATINIUM

DIMENSIONS (bounding box)  
920cm x 650cm x 300cm

90 m<sup>2</sup> 25+ users

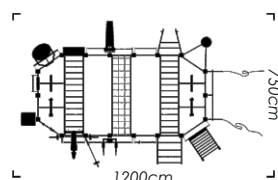

The biggest from Chameleon Family cage allow to train at the same time for 25 people. Every single station can be use in few training prospective, please imagine no limits, no pain, all possibilities in one piece of equipment. Platinum at special order can be even longer! We made the biggest cage in Europe for 40 users allow to train at the same time in Switzerland Army School. All cages from Chameleon line under additional payment can be use outdoor.

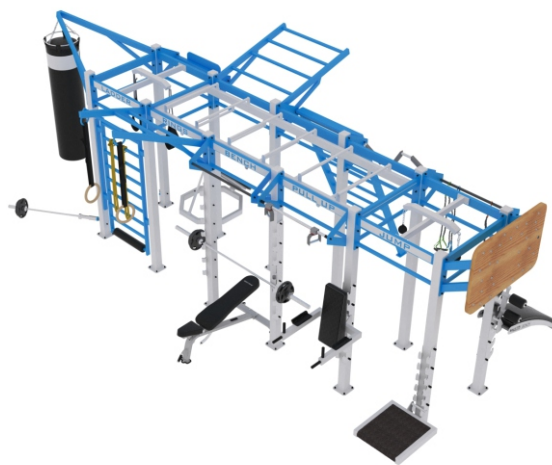

## EXCELLERATE

DIMENSIONS (bounding box)  
745cm x 385cm x 290cm

44 m<sup>2</sup> 15 users

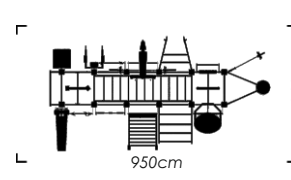

Excelerate is the most unicum model cuz it's takes not a lot of space and it's fully customized with all different stations. 15 people can train at the same time. You can chose any colour from RAL pallet, any station from bigger cages.

rack

Half

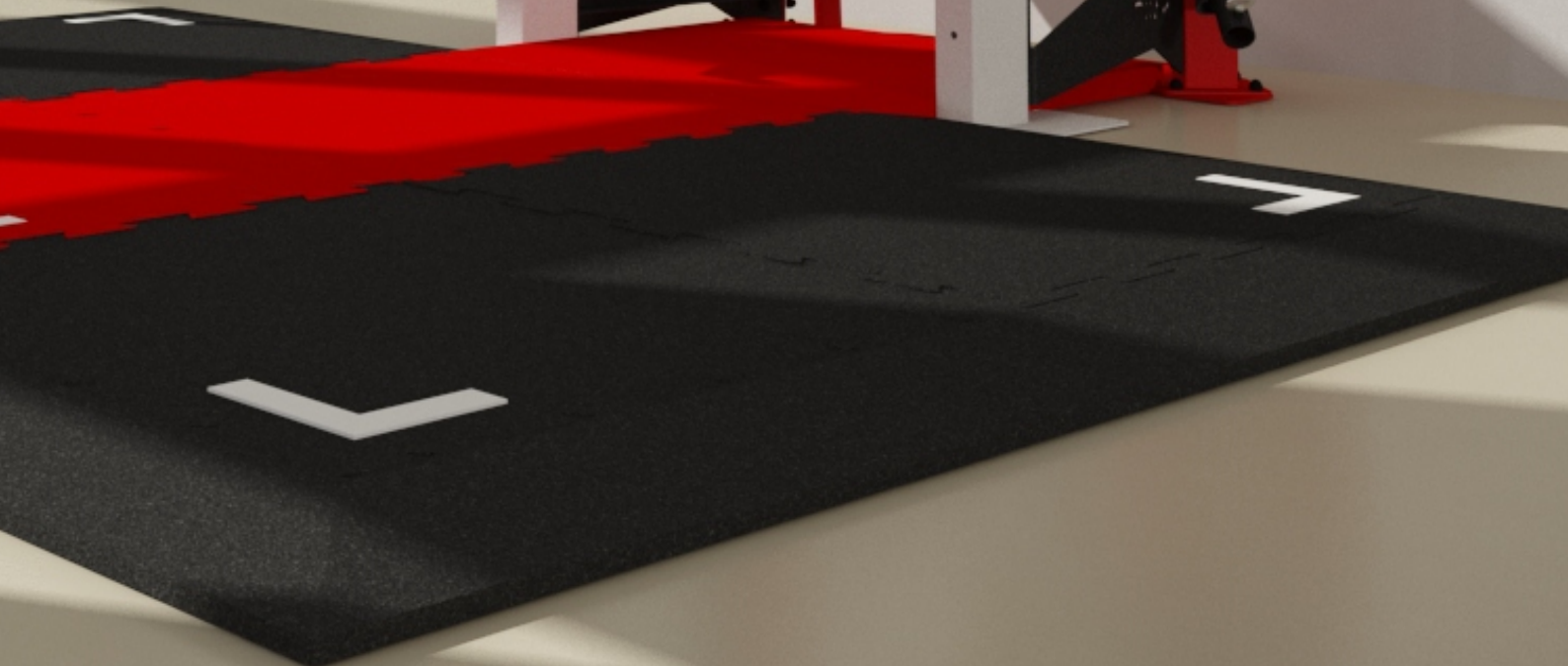



**MINI RACK V3**  
without platform

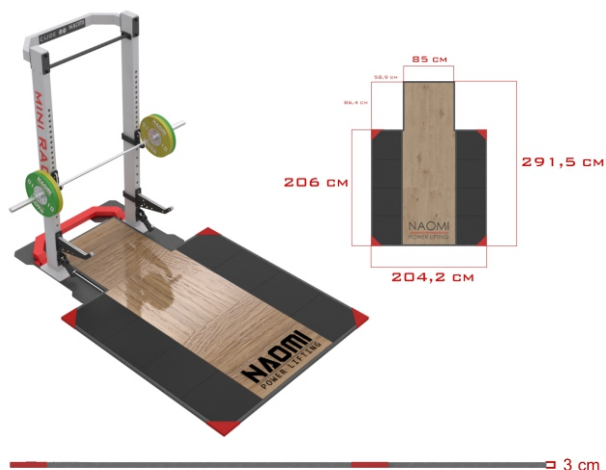

**MINI RACK V3**  
with platform

Mini Rack from Naomi is that piece of equipment you may have in any place. It still very functional and the most power of this little one is space saving.

It's only 115 cm deep and on he's strong post's you still can have safety bars for dead lift's, how cool is that. It is ideal for small studios and large clubs where you can use it with or without weighlifting platform.

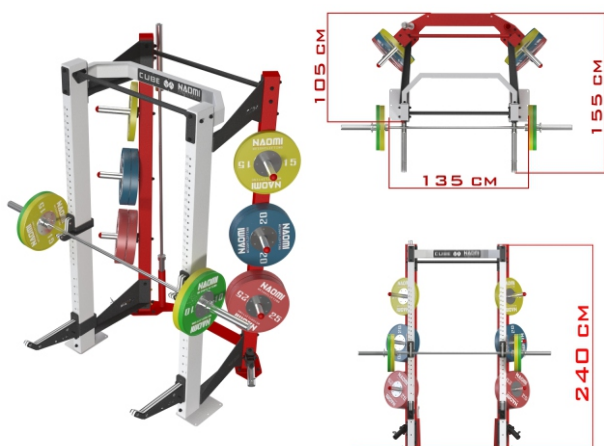

**HALF RACK V3**  
without platform

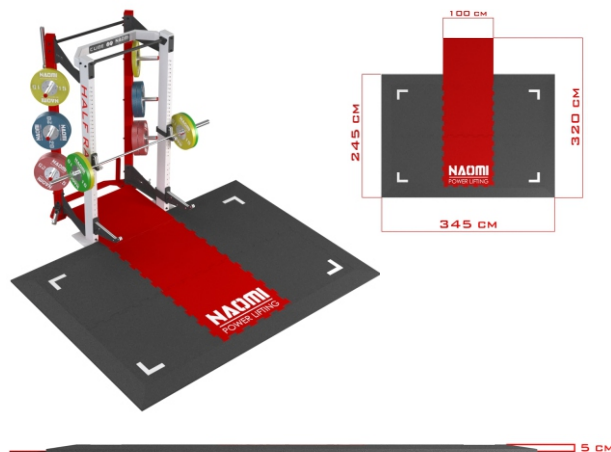

**HALF RACK V3**  
with platform

A Power Rack Line from Naomi is undoubtedly one of the most important pieces of equipment you can have in your gym. Its versatility allows you to perform everything from bench presses to squats. Naomi Power Rack Line is 256cm high and has an inside working space of 100mm, which allows you plenty of room for side-to-side movements. In addition, this power rack offers a total of 23 positions, so it can accommodate a multitude of different heights and exercises. Make this high quality power rack a part of your gym today.

# ABOUT US

Meet three fitness professionals that once upon a time had set out with one idea in mind: to create a valuable and prolific functional fitness product that spans the entire spectrum of fitness. The team recognized an opportunity to create a functional fitness zone that provides unique attributes to better meet customer needs than many look-alike products on the market. By maintaining an efficient and buoyant business structure, we are able to be focused on listening to customers and reacting quickly with creative, innovative ideas that differentiate our products with meaningful functions and features.

Our leaders and team members have played integral roles for many years in the development of critical breakthroughs on functional fitness market. Technical advances found on many of our products are of proprietary designs that are patented and/or patent pending. Our client-focused environment allows us to custom make any project in accordance with the specifications of the end user.

Naomi Fitness Design products are driven by the recognition that it must help health club owners attract and retain members so that they survive and prosper in this challenging environment. This member/end user focus has highlighted the importance that when people will see our products when they walk out onto the exercise floor and how they will feel when they step into your facility. So every product is hard wired into this simple but laser focused design philosophy.

Naomi Fitness Design mission is to provide the world's best and most state-of-the-art functional fitness exercise equipment for people of all ages and activity levels who aspire to live stronger and play harder and better.

# REFERENCES

Our pool of associates and references are extensive. They range from privately held corporations, inclusive of some of the most recognizable fitness chains, all the way down to public schools and colleges as well as armed services throughout the world. Our products can be found in across 6 continents.

AMONG OUR PARTNERS ARE PLACES SUCH AS:

## YMCA **USA**

Cicccone Family Fitness Center - **USA**

Xtreme Fitness - **Poland**

Fitness Plus - **Switzerland**

Fitness Center Baden - **Switzerland**

Switzerland Army Training Academy

Fitness Center Baden - **Switzerland**

Balboa Fitness GmbH - **Switzerland**

Born to Move AG - **Switzerland**

XTRAFIT - **Germany**

Vision - Body - **Germany**

Centiness - **Germany**

Mickey Edwards Training Academy - **UK**

Nolan Health & Center Enniscorthy - **Ireland**

Health City Fitness & More - **Italy**

Feelness - **Spain**

Anytime Fitness - **Spain**

Sarl Fitness Club - **France**

Royal Danish Military Academy - **Denmark**

Eintracht - **Frankfurt**

Legia - **Warsaw**

Airbus - **France**

Rafa Nadal Academy - **Kuwait**

UFC Gyms

# NAOMI WARRANTY

10 / 6 years for structure and welding.

5 years against manufacturing defects affecting the structure.

6 months for upholstery.

90 days in other parts not listed in this warranty.

COM  
DESIGN





[www.naomifitnessdesign.com](http://www.naomifitnessdesign.com)



+48 881 912 539



[sales@naomifitnessdesign.com](mailto:sales@naomifitnessdesign.com)



[facebook.com/naomifitnessdesign/](https://facebook.com/naomifitnessdesign/)



[@naomifitnessdesign](https://twitter.com/naomifitnessdesign)



[#naomifitnessdesign](https://instagram.com/naomifitnessdesign)



*/ SportiC  
/ Duboisa 103  
/ 07-300 Ostrów Mazowiecka  
/ Poland  
/ Mobile: 0048 881912 539*

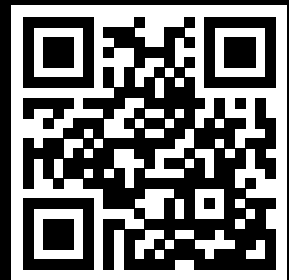

**European Funds**  
Eastern Poland



**European Union**  
European Regional  
Development Fund

