



*TRAIN THE WAY
YOUR BODY MOVES*



FOLD-AWAY STRENGTH TRAINER

TRAIN THE WAY YOUR BODY MOVES

The all new Fg Fold Away Strength Trainer is a dual weight stack gym that offers true independent functional training packaged in a fold-away footprint. With two adjustable swivel pulleys - each with 17 positions - and two different widths, the Fg accommodates users in performing unlimited movements. The docking station for the optional flat-to-incline bench automatically aligns exercisers in the correct position, and the multi-use chin-up/press assist strap enables users of all skill levels to perform exercises they otherwise couldn't do. Plus, the cable columns, bench, and optional exercise balls and training accessories all can be hidden away inside the attractive closing doors. Equipped with several standard accessories, the Fg provides unlimited functional variety for training.

Dimensions (doors closed)	L x W x H: 37.7" x 37.7" x 83.8" (96 cm x 96 cm x 213 cm)
Dimensions (doors open)	L x W x H: 64.4" x 64.4" x 83.8" (163 cm x 163 cm x 213 cm)
Machine weight	610 lbs (277 kg) including two 150 lb (68 kg) weight stacks
Weight stack	Two 150 lb (68 kg), 200 (90.7 kg), or 225 (102 kg) weight stacks
Weight ratio	0.5:1 each pulley
Cable travel (150lb stack)	94" (238cm) each cable with 150 lb (68 kg) weight stacks
Frame	Heavy-gauge 3" x 2" (75 mm x 50 mm) tubing
Finish	Black Jack Matte & Platinum Silver electrostatic powder coat paint and chrome plating
Cables	1/8" (3 mm) military spec 7 x 19 strand internally lubricated cables coated with 3/16" (5 mm) nylon jacket - rated for 2000 lb. tensile strength
Pulleys	Nylon/fiberglass, ABEC-rated maintenance free ball bearings for added durability and smooth feel
Included accessories	T-grip short strap handles, chin-up/push-up assist strap, leg boot, squat harness, and snap hooks
Included workout book	Yes
Workout videos	Online workout videos
Bench	Flat-Incline Bench optional
Optional accessories	See website
Total body training capabilities	Yes

Patented Adjustable Column Width

Elevated door latches help keep the system locked and safe when not in use and provide two column widths - 46" (117cm) and 57" (145cm) that provide unrestricted movement through multiple planes.

Multi-Grip Pull-Up Handles

Ergonomic handles allow for multiple pull-up grip positions and with included assist strap allow anyone to progress.

Accessory storage/Information zone

Places workout manual or iPad in viewable location while storing included strap handles, squat strap, chin-up/push-up assist strap, leg boot, and optional accessories.

Dual Adjustable Swivel Pulleys

Feature one-handed adjustments that have 17 positions in 3.9" (10 cm) increments and provide 95" (241 cm) of travel for virtually any movement.

Dual Cable Columns & Weight Stacks

Chrome plated adjustable cable column uprights with engraved locating numbers and dual 150 lb (68 kg) weight stacks provide smooth adjustment and operation.

Docking station

Positions optional flat-incline bench to correctly align user for all exercises without any guess work.

Noise Dampening Wood Shrouds

Carbon finished composite wood shrouds absorb sound and provide sophisticated industrial aesthetics.

Optional Flat-Incline Bench

Flat-to-incline bench - Integrates with docking location, stores inside enclosure, and features five different back pad positions (0°, >>30°, 45°, 60°, 75°) and two seat pad angles (0°, -15°) all operated with fingertip selection.



FOLD-AWAY STRENGTH TRAINER



WARRANTY

Frame and welds
Parts
Upholstery, cables, grips, handles

RESIDENTIAL

Lifetime
Lifetime
10 years

COMMERCIAL

10 years
1 year
90 days

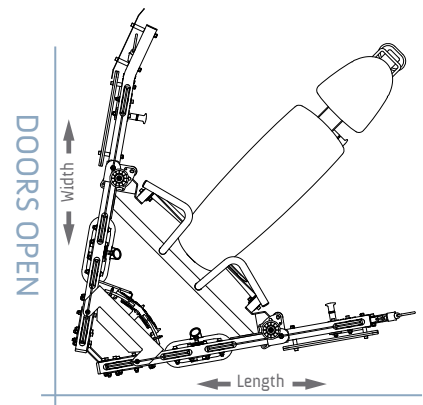
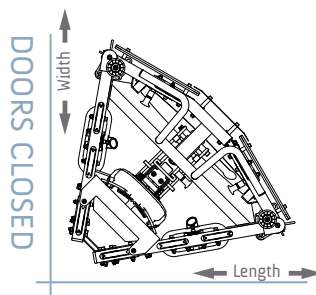

Torque Fitness
11201 Xeon St NW
Suite 101
Coon Rapids, MN 55448
sales@torquefitness.com
763-754-7533
www.torquefitness.com

